

NOW A

**MOORE  
INDUSTRIES**  
The Interface Solution Experts

PRODUCT!

535



535

## 1 / 4 DIN PROCESS CONTROLLER

- ▶ Single Loop
- ▶ Profile Controller (optional)
- ▶ NEMA 4X Front Panel
- ▶ PowerTune®

**MOORE  
INDUSTRIES**

The Interface Solution Experts  
[www.miinet.com](http://www.miinet.com)

## DESCRIPTION

The 535 is a 1/4 DIN single loop process controller (SLC) designed to control any analog process variable (temperature, pressure, flow, level, etc.) in batch and continuous processes. The 535's outstanding feature mix enables it to bring processes under control faster, more accurately and easily than competitive SLC's, PLC, and PC based control systems.

The 535 is widely considered to be a best-in-class instrument due to three fundamental strengths.

### Rugged Construction

- NEMA 4x front panel
- Thick damage resistant keys
- EMI/RFI resistance
- Input/output isolation

### Operator Interface

- 3 line vacuum fluorescent display
- English prompts/messages
- Key color state indication

### Tuning and Control Algorithms

- Powertune - Adaptive tuning
- Powertune - Pretuning
- Powertune - Powerback anti overshoot
- 8 stored PID sets
- Multiple output algorithms

Expanded information about these strengths is detailed throughout this brochure.

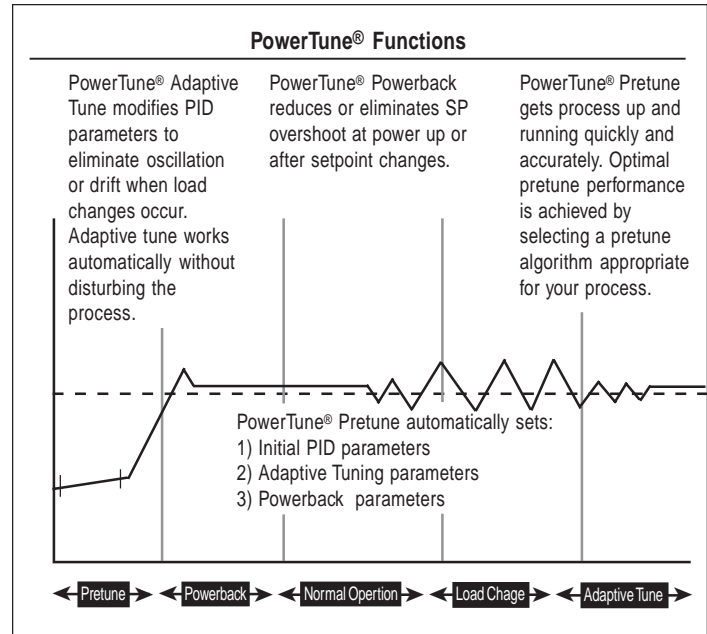

Four Field changeable output module locations (mA, Relay, SSR, DC, Logic, Loop Power)

Two Universal (U, mA, RTD, T/C) PV inputs

Option board I/O

- RSP
- 5 contact inputs
- Actuator Slideware

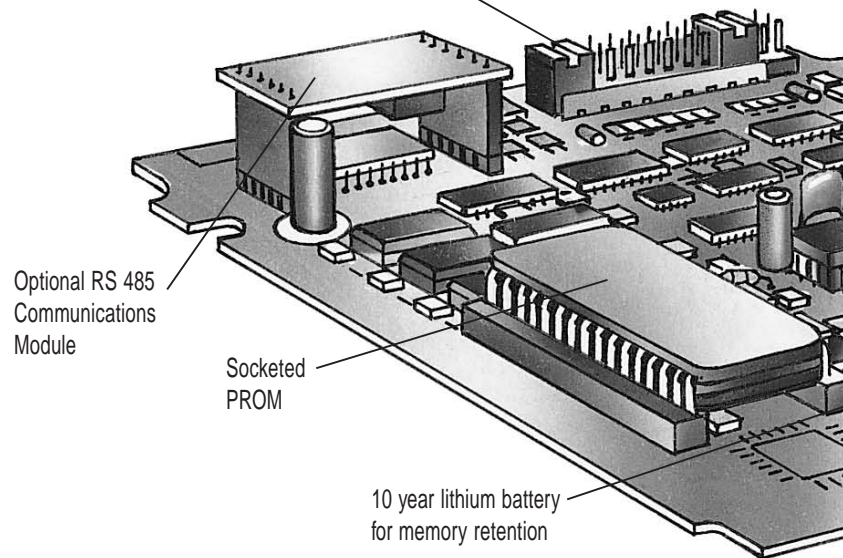

# FEATURE ILLUSTRATION

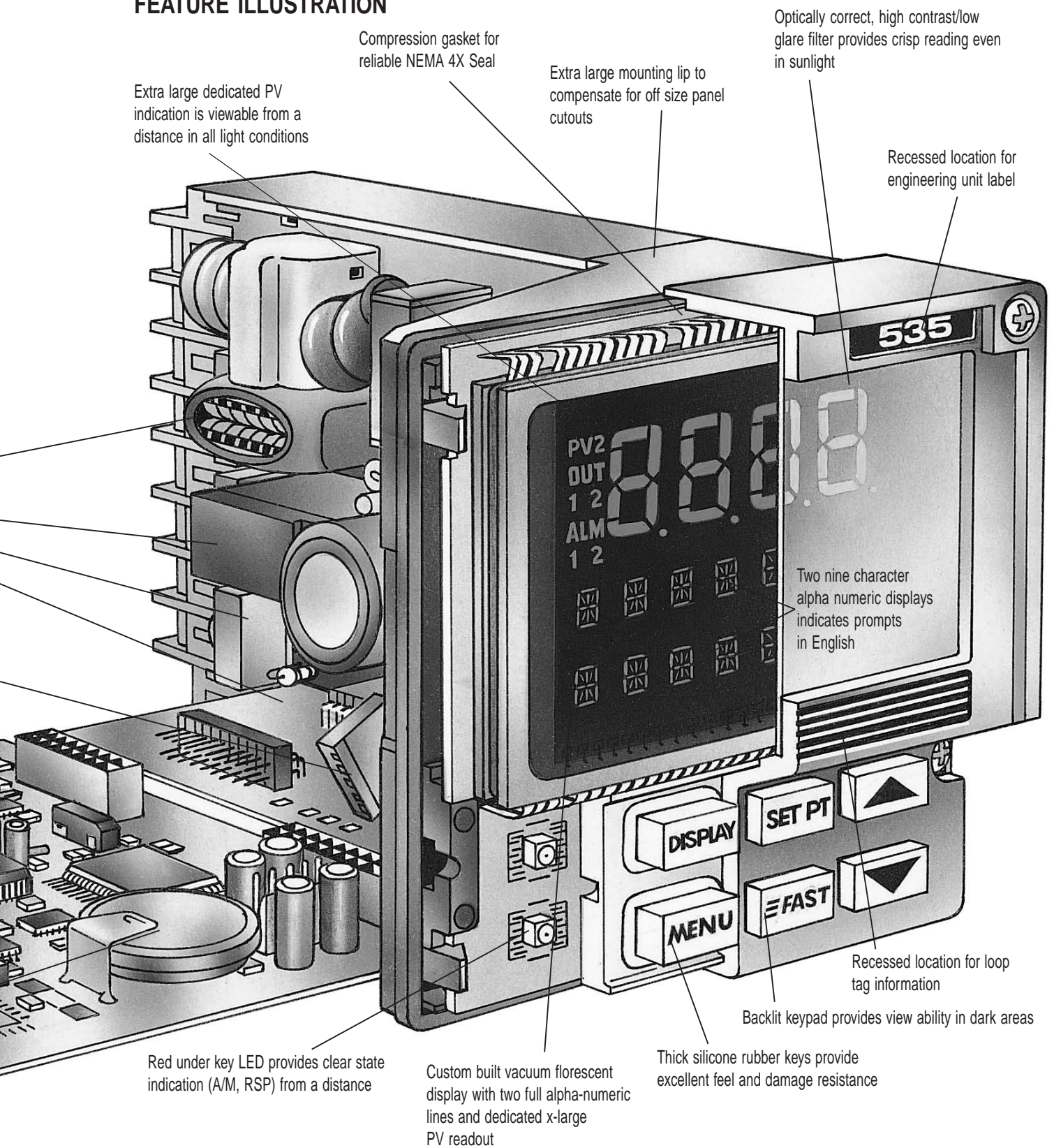

Extra large dedicated PV indication is viewable from a distance in all light conditions

Compression gasket for reliable NEMA 4X Seal

Extra large mounting lip to compensate for off size panel cutouts

Optically correct, high contrast/low glare filter provides crisp reading even in sunlight

Recessed location for engineering unit label

Two nine character alpha numeric displays indicates prompts in English

Red under key LED provides clear state indication (A/M, RSP) from a distance

Custom built vacuum florescent display with two full alpha-numeric lines and dedicated x-large PV readout

Thick silicone rubber keys provide excellent feel and damage resistance

Recessed location for loop tag information

Backlit keypad provides view ability in dark areas

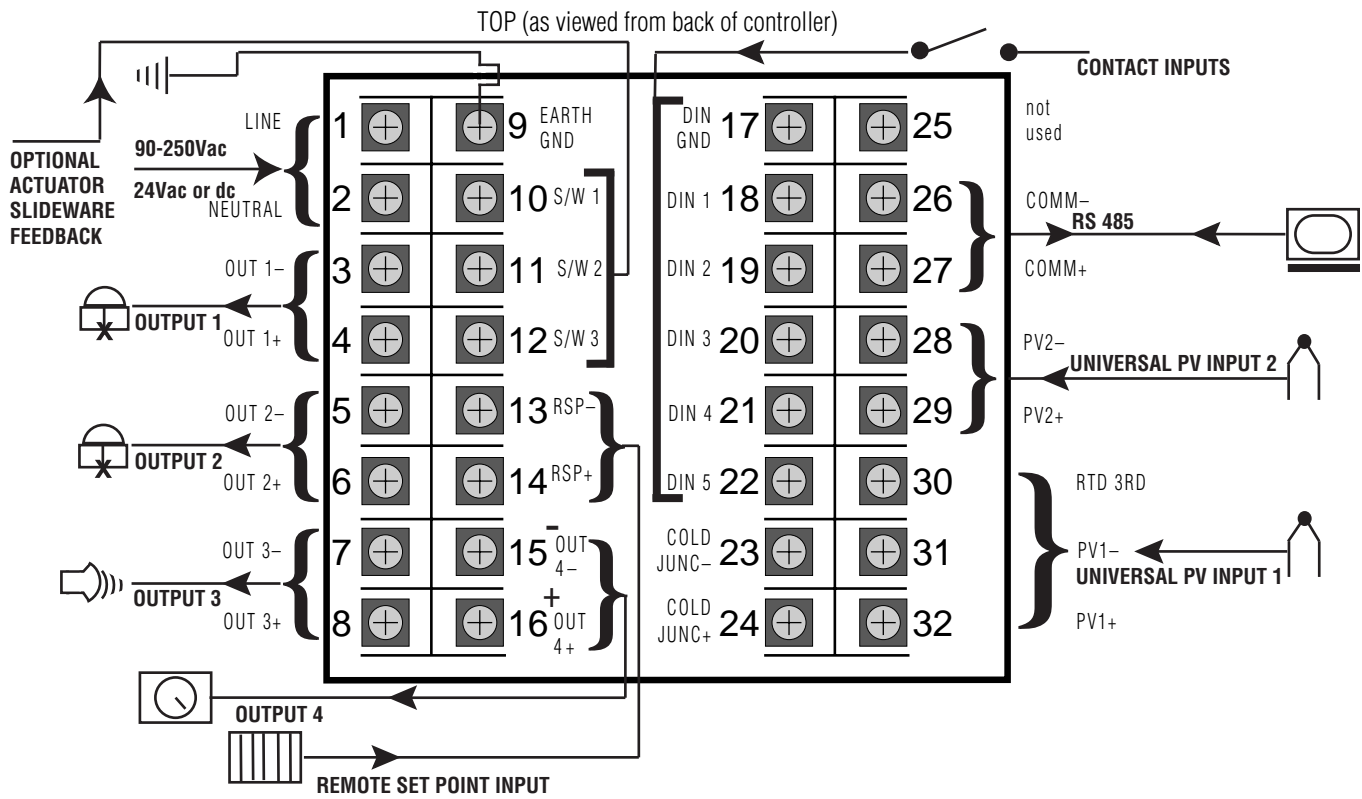

### Input Functions

PV Input (Universal)	RSP Input (Optional)	Contact Inputs (Optional)
PV1 PV2 Switch on demand	Range	Activate RSP
PV1 PV2 Switch on PV1 failure	Bias	Trip to Manual
PV1 - PV2	Gain	Lock in Manual mode
PV1 + PV2	Local SP Tracking	Select Alternate SP (1-8)
Average of PV1, PV2		Select Alternate PID (1-8)
High Select		Acknowledge Alarm
Low Select		Inhibit Integral Control
		Invert Control Action
		Inhibit Adaptive Tuning
		Emulate Front panel Keys
		Digital Input for Data Acquisition

### Output Functions

Outputs are plug-in modules.

Types include: Analog (mA), Mechanical Relay, Solid State Relay, DC Logic, and Loop Power.

Output 1	Output 2	Output 3	Output 4
Control	Second Control	Alarm	Alarm
	Alarm	Retransmission	Retransmission
	Retransmission	RS 485 Driver	RS 485 Driver
	RS 485 Driver	Loop Power	Loop Power

## INPUT FUNCTIONS

### PROCESS VARIABLE

Two universal inputs are available. Any input type may be field selected via jumper. Dual inputs may be used to:

- Select input on demand
- Switch upon failure
- Derive a PV by subtracting (PV1 - PV2)
- Derive a PV by adding (PV1 + PV2)
- Derive a PV by averaging (PV1 + PV2)/2
- Select highest PV
- Select lowest PV

THERMOCOUPLES	RANGE °F	RANGE °C
B	104 to 3301	40 to 1816
E	-454 to 1832	-270 to 1000
J	-346 to 1832	-210 to 1000
K	-418 to 2500	-250 to 1371
N	-328 to 2372	-200 to 1300
R	32 to 3182	0 to 1750
S	32 to 3182	0 to 1750
T	-328 to 752	-200 to 400
W	32 to 4172	0 to 2300
W5	32 to 4172	0 to 2300
Platinel II	-148 to 2550	-100 to 1399

RTDs	RANGE °F	RANGE °C
100ohm Pt.(DIN)	-328 to 1562	-200 to 850
	-328.0 to 545.0	-200.0 to 285.0
100ohm Pt.(JIS)	-328 to 1202	-200 to 650
	-328.0 to 545.0	-200.0 to 285.0
100ohm Pt.(SAMA)	-328 to 1202	-200 to 650
	-328.0 to 545.0	-200.0 to 285.0

Transmitter Signals	Input Range
Milliamps DC	4 to 20 0 to 20
Voltage DC	1 to 5 0 to 5
Millivolts DC	0 to 10 0 to 30 0 to 60 0 to 100 -25 to 25

### ACCURACY

	TYPICAL	MAXIMUM
<b>LINEAR</b> (Voltage)	± 0.025% of full scale	± 0.100% of full scale
(Current)	± 0.050% of full scale	± 0.150% of full scale
<b>RTD</b> 1°	± 0.050% of span	± 0.150% of span
0.1°	± 0.095% of span	± 0.225% of span
<b>THERMOCOUPLE</b>		
J, K, N, E (> 0°C)	± 0.060% of span	± 0.150% of span
J, K, N, E (< 0°C)	± 0.150% of span	± 0.375% of span
T (> 0°C)	± 0.100% of span	± 0.250% of span
T (< 0°C)	± 0.250% of span	± 0.625% of span
R, S (> 500°C)	± 0.150% of span	± 0.375% of span
R, S (< 500°C)	± 0.375% of span	± 0.925% of span
B (> 500°C)	± 0.150% of span	± 0.375% of span
B (< 500°C)	± 0.500% of span	± 1.000% of span
W, W5 & Platinel II	± 0.125% of span	± 0.325% of span

Display accuracy is ± 1 digit.

These accuracy specifications are at reference conditions (25°C) and only apply for NIST ranges. Detailed accuracy information is available upon request.

### LINEARIZATION

Thermocouple and RTD inputs are automatically linearized. Transmitter inputs may be linearized with a square root function or user-defineable 15-point straight line linearization function.

### INPUT IMPEDANCE

Current Input: 250ohms Thermocouples: 10Mohms  
Voltage Input: 1Mohm RTDs: 10Mohms

### UPDATE RATE

Input is sampled and output updated 10 times per second. Display is updated five times per second.

### TRANSMITTER LOOP POWER

Isolated 24Vdc (nominal) loop power supply is available if a loop power module is installed in an output socket not used for control. Capacity is 25mA.

### INPUT SIGNAL FAILURE PROTECTION

When input is lost, output is commanded to a predetermined output (-5 to 105%). Thermocouple burnout is selectable for upscale or downscale.

### INPUT FILTER

Single pole lowpass digital filter with selectable time constant from 0 to 120 seconds.

### CALIBRATION

Comes fully calibrated from the factory and continuously calibrates itself for component aging due to temperature and time, except for the reference voltage. Field calibration can be easily performed in the field with a precision multimeter and thermocouple simulator. Process variable offset and gain factors are provided to correct for sensor errors.

### SETPOINT SELECTION

A remote setpoint input is available. Signal is 0-20/4-20mAdc or 0-5/1-5Vdc (jumper selectable). Signal may be ratioed and biased. Eight local setpoints may be stored in memory.

Setpoint selection is made via SET PT key or digital contact(s).

### DIGITAL INPUTS

A set of five external dry contacts or open collector transistor driven inputs are available. Each can be configured to perform one of the following functions:

- Select remote setpoint
- Select either direct or reverse control action
- Select manual control
- Addressable through serial communications only
- Select second local setpoint
- Inhibit the reset term
- Select a second set of PID values
- Lock controller in manual mode
- Acknowledge alarms
- Simulate DISPLAY, FAST, and MENU keys
- Disable adaptive tuning

In addition, if the set of five digital inputs is installed, four may be designated to select one of eight local setpoints (and associated PID set, if desired) via a binary coded decimal (BCD) input.

---

## OUTPUT FUNCTIONS

### OUTPUT MODULES

The controller can have a total of four control outputs, alarm outputs and/or loop power modules installed. There are five types of output modules which can be configured to suit your particular application. The modules may be ordered factory-installed, or they may be installed in the field.

**Analog module:** Either 0-20mA or 4-20mA (front panel selectable) into a load up to 1000ohms. Accuracy  $\pm 15$  microamps@25°C.

**Mechanical relay module:** SPDT electromechanical relay. Resistive load rated at 5 amps at 120/240Vac. Normally open or normally closed selection is made by jumper. Output 4 is rated at 0.5 amps at 24Vac and is always normally open.

**Solid state relay (triac) module:** Resistive load rated at 1 amp at 120/240Vac. Output 4 is rated at 0.5 amps at 24Vac. These outputs are normally open.

**DC logic (SSR drive) module:** "On" voltage is 17Vdc (nominal). "OFF" voltage is less than 0.5Vdc. (Current limited to 40mA.)

**Loop power supply module:** Current is limited to 25mA@24V.

### Control Outputs

Up to two output modules may be designated for control. Any combination of output modules, with the exception of the loop power supply module, may be used.

**Duplex control** is available if output modules are installed in the first and second output sockets.

**Position proportioning control** with feedback is available if mechanical or solid state relay modules are installed in the first two output sockets, and the slidewire feedback option is installed. Slidewire feedback range is 0 to 1050ohms.

**"Velocity" position proportioning control** is available by installing mechanical or solid state relay modules in the first two output sockets. A special time based algorithm controls an electric actuator without the slidewire feedback signal.

**Staged (split range) outputs** are available if analog modules are installed in the first and second output sockets. This algorithm will allow the output range to be split between the two outputs.

### CONTROL ALGORITHM

PID, P with manual reset, PI, PD with manual reset, and On-Off are selectable from the front panel. Duplex outputs each use the same algorithm, except On-Off may be used with PID. The PID algorithm used is non-interacting.

### TUNING PARAMETERS

**Proportional Band:** 0.1 to 999% of input range

**Integral:** 1 to 9999 seconds/repeat

**Derivative:** 0 to 600 seconds

**Manual Reset/Load Line:** 0 to 100% output

**Cycle Time:** 0.3 to 120 seconds

**On-Off Deadband:** up to 15% of input range (in eng. units)

Up to eight sets of PID values may be stored in memory and selected automatically, based on setpoint value, process variable value, or the corresponding local setpoint (SP1-SP8)

### Retransmission Output

Based on available outputs (any socket not used for control), up to two different variables can be simultaneously programmed for retransmission. Each precise, 16-bit resolution output may be scaled for any range. Variable selection includes: PV, SP, RAMP, SP, and OUTPUT.

### Transmitter Loop Power

Isolated 24Vdc (nominal) loop power supply is available if a loop power module is installed in an output socket not used for control. Capacity is 25mA. Two or four wire transmitters can be powered.

### ALARMS

The 535 controller has two software alarms. High and low alarms may be sourced to:

- Process Variable High
- Process Variable Low
- Process Variable High & Low
- Deviation from S.P.
- Band around S.P.
- Rate of Change
- Manual Control Module
- Remote S.P.
- Control Output

If an alarm is tripped, the alarm message will show, the ACK key will illuminate (if acknowledgeable) and the ALM icon will light. If the alarm is tied to the first available non-control output, the "1" below the ALM icon will light. Similarly, if the alarm is tied to the second non-control output, the "2" below the ALM will light. The availability of outputs determines how many alarms can be tied to relays.

Up to two alarm outputs are available if an associated mechanical, solid state relay or DC logic module is installed in any output socket not used for control.

**Global Alarm** feature allows one or more of the internal software alarms to be tied to the same single, physical output. The acknowledge key is active for alarms associated with either loop.

## PROFILE CONTROL OPTION

The 535 Profile Controller's unique operator interface makes it simple to set up and operate while retaining powerful profile functions detailed below. The 535 can store 20 recipes, with a sample shown below. Recipes are selectable via front panel, contact inputs, or serial communications. Recipes may be linked to create extra-long recipes.

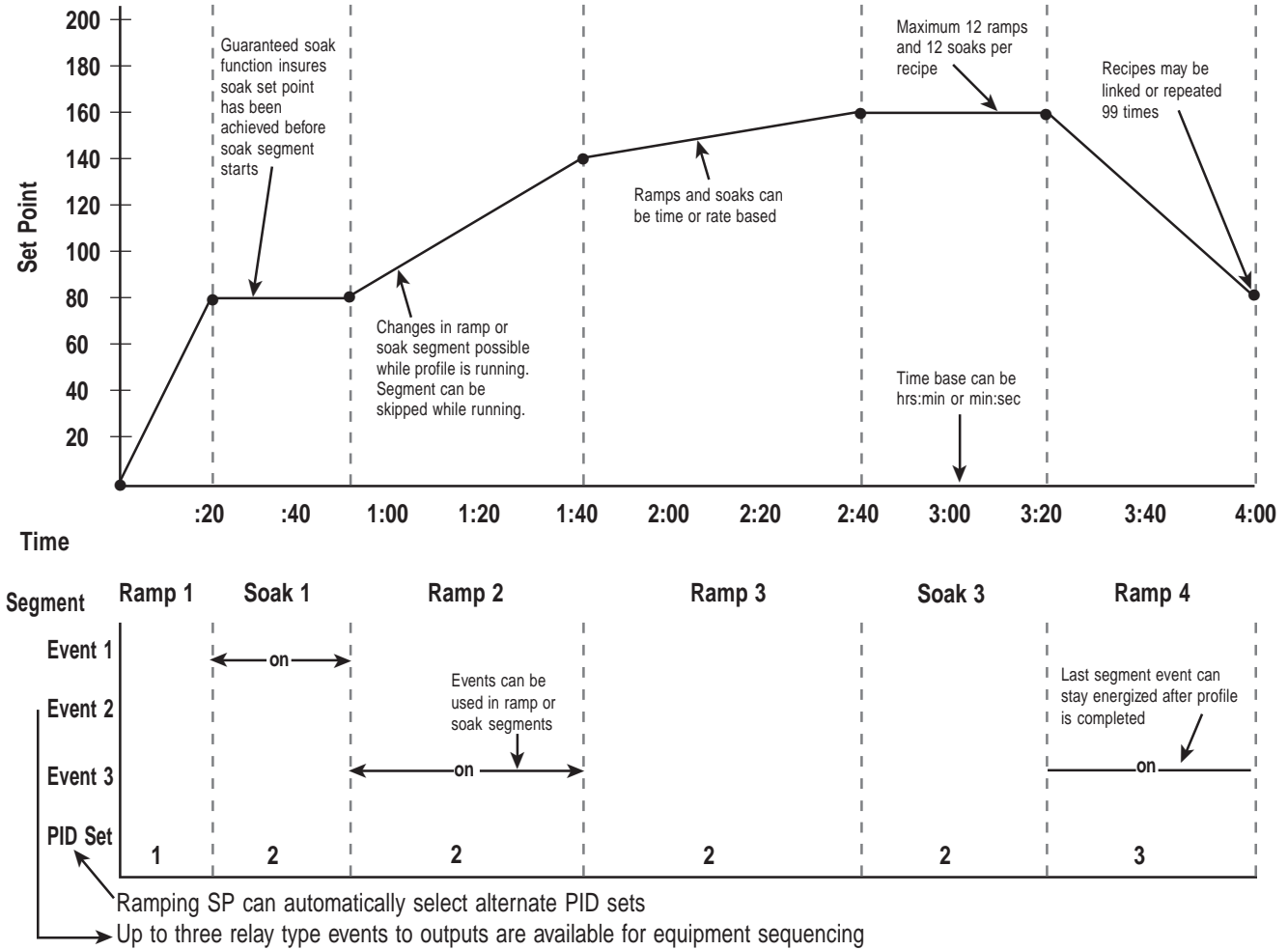

### Special Profile I/O

Power Restoration Modes:  
 1) RESUME recipe where it left off  
 2) HOLD at last SP prior to power loss  
 3) ABORT recipe  
 4) RESTART recipe

Outputs 2-4  
 • Event outputs  
 • SP retransmission to slave controller  
 • Alarm output  
 • Second Control output

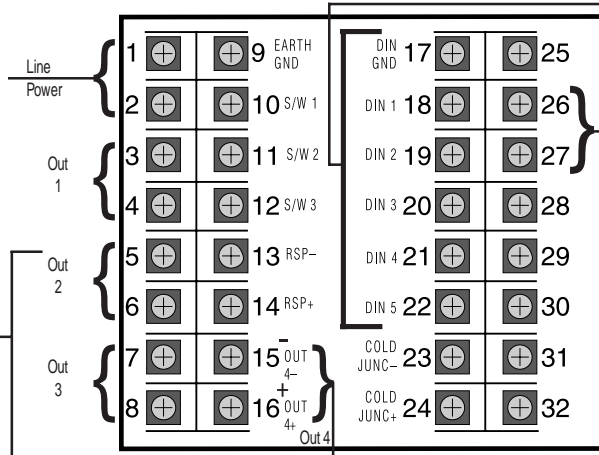

#### Contact Inputs:

- Start Recipe
- Hold Recipe
- Reset Recipe
- Skip to next segment
- Abort Recipe
- Recipe 1-7 selection

#### RS 485:

All profile configuration and operation are accessible through serial communication

## GENERAL SPECIFICATIONS

### CONTROLLER ARCHITECTURE

The 535 Controller hardware can be configured as follows:

**Inputs:** Two universal process variable inputs are standard. Available options include: remote setpoint, slidewire feedback and 5 digital inputs.

**Outputs:** Four outputs are available. See Ordering Information. RS-485 Communications: Available as option with any configuration.

### SERIAL COMMUNICATIONS

Isolated serial communications is available using an RS-485 interface. Baud rates of up to 19,600 are selectable. The protocol supports CRC data checking. If communications are lost, a time-out feature will command the controller to a particular control mode and specific setpoint or output if desired. Outputs 2-4 and digital inputs can act as "host-controlled" I/O independent of the controller's function. The PV may be sourced via this interface. May be installed in the field.

### DIGITAL DISPLAYS

**Upper display:** five-digit, seven-segment. Used exclusively for displaying the process variable value. Height is 15mm (0.6 in.).

**2nd display:** nine-character, 14-segment alphanumeric. Used for displaying setpoint, deviation, output value, slidewire position (actual valve position) and configuration information. Height is 6mm (0.25 in.).

**3rd display:** nine-character, 14-segment alphanumeric. Used for indicating which loop is displayed and for displaying alarm messages and configuration information. Height is 6mm (0.25 in.).

All displays are vacuum fluorescent. Color is blue-green.

### STATUS INDICATORS

There are two types of indicators: icons and illuminated keys.

**ALM 1 and ALM 2 icons:** alarm 1 and alarm 2 status.

**OUT 1 and OUT 2 icons:** control output 1 and control output 2 status.

**MAN key illuminated:** controller is in manual control mode.

**ACK key illuminated:** alarm may be acknowledged.

**SET PT key illuminated:** setpoint other than primary local setpoint is active.

**MENU key illuminated:** controller is in configuration mode.

### MOUNTING

Panel-mounted.

### WIRING CONNECTIONS

29 screw terminals in the rear of the instrument.

### POWER CONSUMPTION

15VA at 120Vac, 60Hz (typical).

### WEIGHT

Approximately 1 kg (2.2 lbs.).

### AMBIENT TEMPERATURE

Operative Limits: 0 to 50°C (32 to 122°F).

Storage Limits: -40 to 70°C (-40 to 158°F).

### RELATIVE HUMIDITY

10 to 90%, non-condensing.

### VOLTAGE AND FREQUENCY

Universal power supply: 90 to 250Vac, 48 to 62Hz. 24V (AC or DC power optional).

### NOISE IMMUNITY

Common mode rejection (process input): >120 dB.

Normal mode rejection (process input): >80 dB.

AC line is double filtered and transient protected. Snubbers are provided for each relay output.

### ISOLATION

Inputs and outputs are grouped into the following blocks:

**Block 1:** process variable

**Block 2:** outputs 1, 2, and 4

**Block 3:** communications, set of five digital inputs, output 3 (Earth Ground)

**Block 4:** remote setpoint

Each block is electrically isolated from the other blocks to withstand a HIPOT potential of 500Vac for 1 minute or 600Vac for 1 second, with the exception of blocks 1 and 4, which are isolated to withstand a HIPOT potential of 50 volts peak for 1 minute between each other. Inputs and outputs are not isolated from other inputs and outputs within the same block.

### CONSTRUCTION

**Case:** flame resistant ABS

**Chassis assembly:** plug-in type.

**Keys:** silicone rubber with diffusion printed graphics.

**NEMA rating:** front panel conforms to NEMA 4X when instrument is properly installed.

### AGENCY APPROVALS



LISTED  
Process Control Equipment  
4N66



(Heavy Industrial)

(Available as an option)

### MEMORY RETENTION

Lithium battery maintains all programming for approximately ten years.



## SECURITY

There are two levels of access: restricted and full. A configurable code is used to enter the full access level. Functions not available in the restricted level are configurable. Six different groups of parameters can be restricted.

## PROFILE CONTROLLER OPTION

When a 535 is specified as a profile controller, the SET PT (setpoint key) is replaced at the factory with a RUN key to facilitate operation. Setpoint access is available through use of the DISPLAY key. All functions are described in the manual supplement. The 535 with profile option, provides full ramp and soak capability with the following features:

### 20 RECIPES/PROGRAMS

Up to 20 recipes/programs may be stored in memory and recalled by number through the front panel keys, digital inputs or RS-485 Communications.

### 24 SEGMENTS PER RECIPE

12 ramps and 12 dwells may be programmed for each recipe. Programming a dwell time of OFF effectively skips the dwell allowing 2 consecutive ramps of different rates. Recipes may be linked if more than 24 segments are necessary.

### GUARANTEED SOAK WITH ADJUSTABLE HYSTERESIS

When activated, dwell time doesn't start until the ramp setpoint has been achieved within the specified hysteresis (a positive or negative deviation from the dwell setpoint).

### 3 EVENT OUTPUT CAPABILITY

Up to 3 event outputs, programmable per segment, may be selected depending on the availability of controller outputs. The 535 has 4 outputs. If 1 is used for control, 3 are available for events. Likewise, if 1 is for control and 1 for an alarm, 2 are available for events. These outputs are available to turn on fans, start another process and perform other functions.

### RAMPS PROGRAM IN TIME OR RATE

A ramp can be programmed to take place over a specific amount of time or be based on the rate of change of the PV per hour. If time based, the time to reach setpoint must be between 0:01 and 99:59 (hours:minutes). If rate based, the setpoint must be reached at a rate between -9999 and 9999 engineering units per hour.

## DUAL TIME BASE

Two modes are available, Hours:Minutes or Minutes:Seconds

## MULTIPLE CYCLES, 1-99 PER EACH RECIPE

Recipes may be programmed to automatically repeat up to 99 times.

## RECIPE LINKING

All 20 recipes may be linked to form a new longer version. For example, select recipe 4 to automatically follow recipe 2.

## REMOTE FUNCTIONS VIA DIGITAL INPUT

Using the optional digital inputs, the following functions may be remotely activated: Start, Hold, Reset, Abort and Segment advance.

## MODIFY RECIPES WHILE RUNNING

Individual recipes may be modified by the operator while running.

## REMOTE RECIPE CHOICE VIA DIGITAL INPUT

Using the optional digital inputs, recipes 1-7 may be selected remotely.

## POWER RESTORATION MODES

Four different power restoration modes are available. Upon power failure and subsequent return, the controller can either: 1) Resume a recipe where it left off 2) Return to the last output of the recipe and hold it 3) Abort the recipe 4) Start a new recipe automatically.

## TIE PID SETS TO RECIPES OR SEGMENTS

Any one of eight PID sets may be tied to each recipe or segment to optimize control.

## MASTER/SLAVE CAPABILITY

The 535 with profile controller option can retransmit the ramping setpoint to up to four 535s with remote setpoint creating a master/slave relationship. With this capability, 5 loops, each running the same recipe, can be controlled.

## SEGMENT ADVANCE

The operator may advance through the program segments while a recipe is running.

